

**EXCELLENCE  
THROUGH  
EXPERTISE**



**FONTANA  
MACCHINE** S.r.l.

MACCHINE UTENSILI E UTENSILERIA

Via Charta '77, n. 20 - SCANDICCI (FI)  
Tel. 055 7310362 - email [info@fontanamacchine.it](mailto:info@fontanamacchine.it)  
[www.fontanamacchine.it](http://www.fontanamacchine.it)

**53030/500/6040**

**CNC TAPPING CENTER**

**RES·SEIKI**®

# S Series

# 3030/500/6040 CNC DRILLING AND TAPPING CENTER

- HIGH SPEED SPINDLE ■ HIGH RESPONSE SERVO SYSTEM
- HIGH SPEED 3 AXES RAPID TRAVERSE ■ DIRECTLY COUPLED SPINDLE DRIVE SYSTEM
- FULL-TRAVEL COLUMN, DOUBLE WORK STATIONS & HIGHLY RIGID MACHINE STRUCTURE



## A NEW GENERATION OF DRILLING & TAPPING CENTER

### ■ Spindle Speed (STD)

BT30: 10000rpm  
BT40: 8000rpm

### ■ Spindle Speed (OP)

BT30: 12000 / 15000 / 20000rpm  
24000rpm (Mitsubishi)  
BT40: 12000 / 15000rpm

### ■ Tools Capacity

**S3030** BT30: 14 / 20(OP)  
**S500** BT30: 20+1T  
**S6040** BT40: 24+1T

### ■ Rapid Traverse

**S3030**: 48 / 48 / 48m/min  
**S500 / S6040**: 36 / 36 / 48m/min

### ■ Positioning Accuracy

JIS B6338: 0.005 / 300mm  
VDI3441 P: 0.012mm

### ■ Repeatability Accuracy

JIS B6338:  $\pm 0.003$ mm  
VDI3441 P: 0.010mm

### ■ Rigid Tapping

BT30: 4000rpm  
BT40: 3000rpm

**S6040**



**S500**



**S3030**



### FULL-TRAVEL COLUMN STRUCTURE

**Machine Structure** : Manufactured from high rigidity cast iron, the ARES machine structure is computer analyzed for maximum rigidity, fast travel and heavy duty machining conditions.

**Transmission System** : Three axes are equipped with roller guide ways combined with extra long preloaded side blocks for maximum feeding stability.

## DIRECT DRIVE SPINDLE

BT30

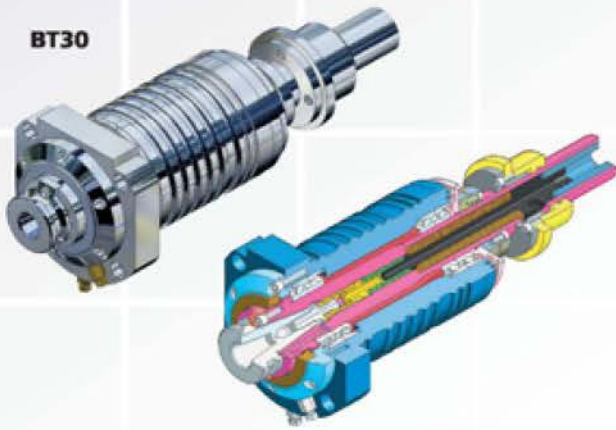

**Spindle :** The directly coupled spindle eliminates power transmission loss to develop the highest efficient of spindle motor. Spindle is mounted on four P4 high precision angular contact ball bearings combined with constant temperature device to provide outstanding richening rigidity.

BT40



## COOLANT THROUGH SPINDLE (OP)



Coolant flow is fed by a high pressure pump through the spindle and out the tip of the cutting tool, immediately reducing any heat at the cut point. This substantially increases the cutting efficiency while extending tool life, this system reduces thermal deformation and provides stable accuracy.

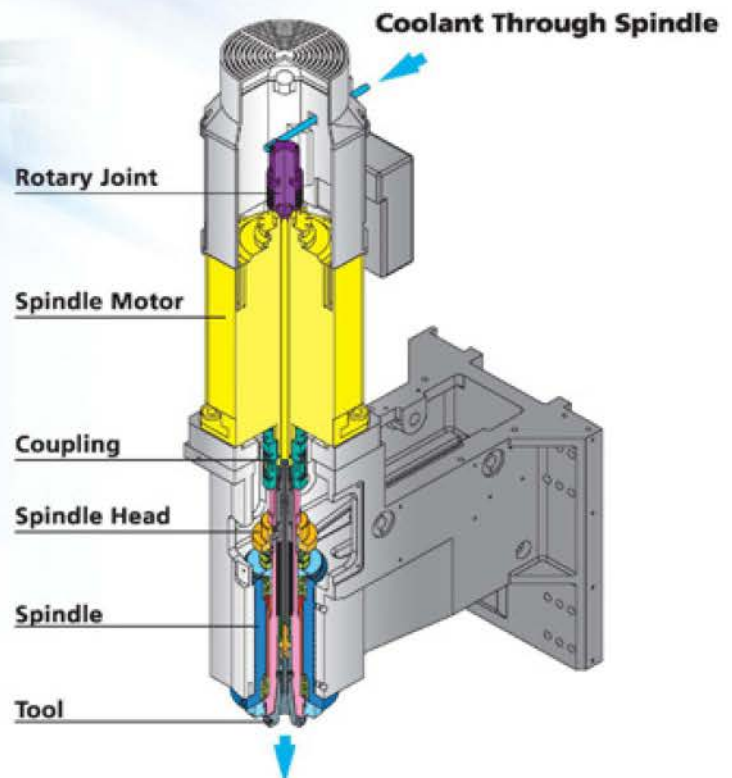

## THE FASTEST SPINDLE ACCELERATION

### Reduced Non-cut Time and Spindle Acceleration / Deceleration

Special design is adopted all new spindle motor. This greatly reduces the response time for rigid tapping, powerful servo motors on 3 axes feature fast acceleration / deceleration time for 3 axes rapid traverses.



S3030: Servo ATC (OP)

## SWING TABLES

The machines are equipped with double work stations. Table changing is performed by 180 degree rotary table for fast and stable motion. The specially designed table positioning mechanism fully prevents chip accumulation that may affect positioning accuracy, which usually occurs on a conventional table change system.

Models with swing tables are especially ideal for those work pieces requiring short machining time but frequent work piece change. The computer features safety protection software to lock table change commands while work pieces are being changed, ensuring fast and safe machining operations.



## Full Enclosed Splash Guard & Oil Mist Collector

S3030

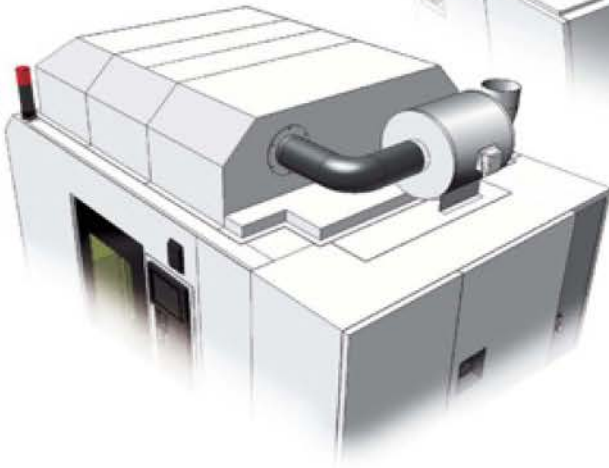

S500

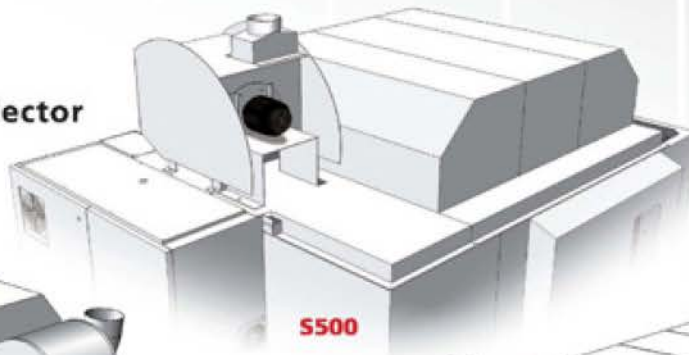

S6040

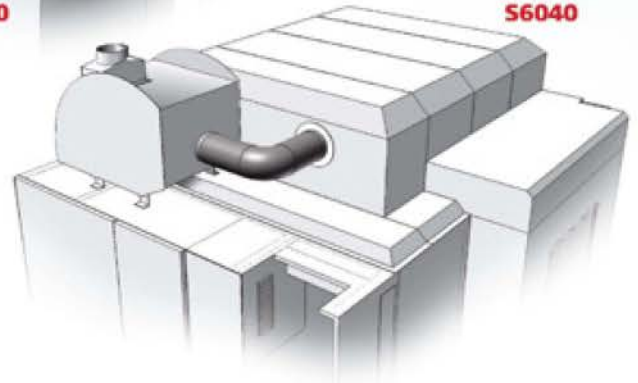

Oil Cooler



CTS Spindle Motor



Water Tank



CTS Filtration

### STANDARD ACCESSORIES

- Toolbox and tools
- Auto. lubrication system
- Tool coolant system
- Spindle air blow system
- Leveling bolts and pads
- Direct spindle drive
- Traveling column machine structure
- Work light
- Dual-color alarm light
- Chip flush system
- Work table hydraulic system (S500)
- Chip conveyor with cart (S500)
- 3 axes with roller guide
- Screw-type chip conveyor (S3030 / S6040)

### OPTIONAL ACCESSORIES

- Transformer / stabilizer
- Work piece air blow system
- Spindle speed
  - BT30: 12,000 / 15,000 / 20,000rpm
  - 24,000rpm (Mitsubishi / Siemens)
  - BT40: 12,000 / 15,000rpm
- High speed spindle (With spindle oil cooling system)
- Coolant through spindle (CTS)
- CTS filtration
- Air gun / water gun
- Surround chip flushing system
- Work table hydraulic system (S6040)
- Chip conveyor with cart (S3030 / S6040)
- Oil / water partition
- Full enclosed splash guard (Top cover)
- Oil mist collector
- High speed & high accuracy machining control mode G05 P20000 (Mitsubishi M80-A)
- The 4<sup>th</sup> axis (S500 / S6040)
- Servo ATC (S3030)
- CE



# S Series 3030/500/6040 CNC TAPPING CENTER

## S3030 MACHINE DIMENSIONS

Unit : mm

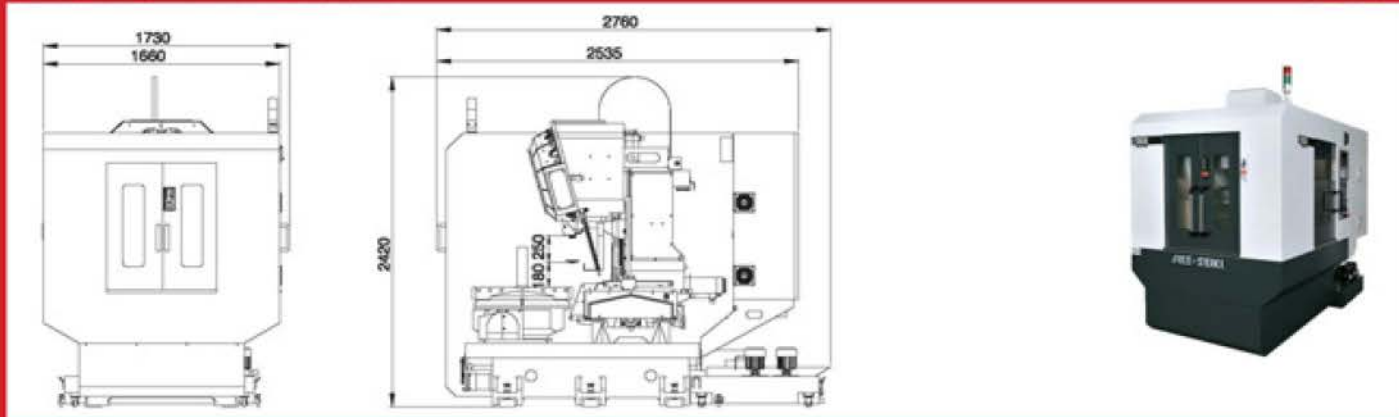

## S500 MACHINE DIMENSIONS

Unit : mm

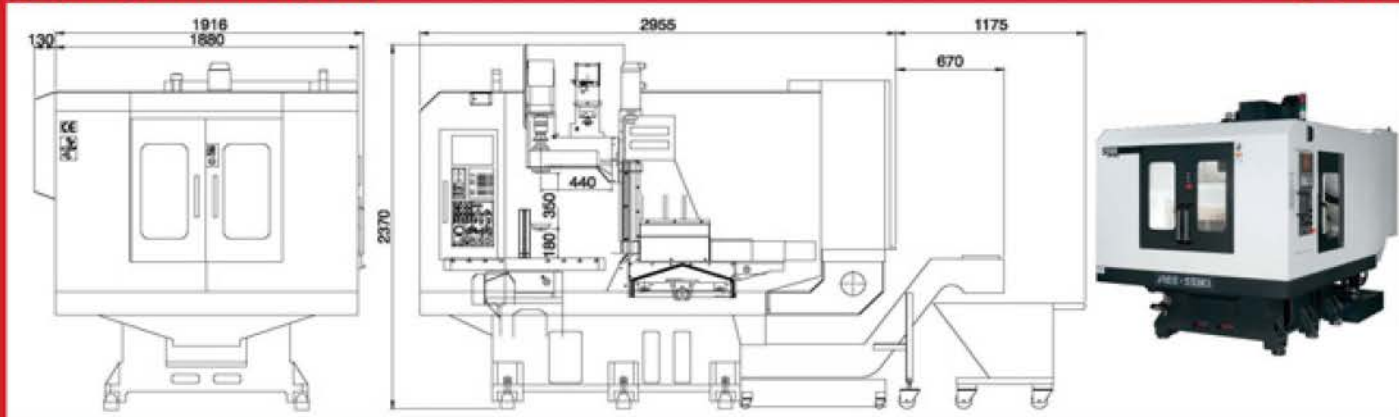

## S6040 MACHINE DIMENSIONS

Unit : mm

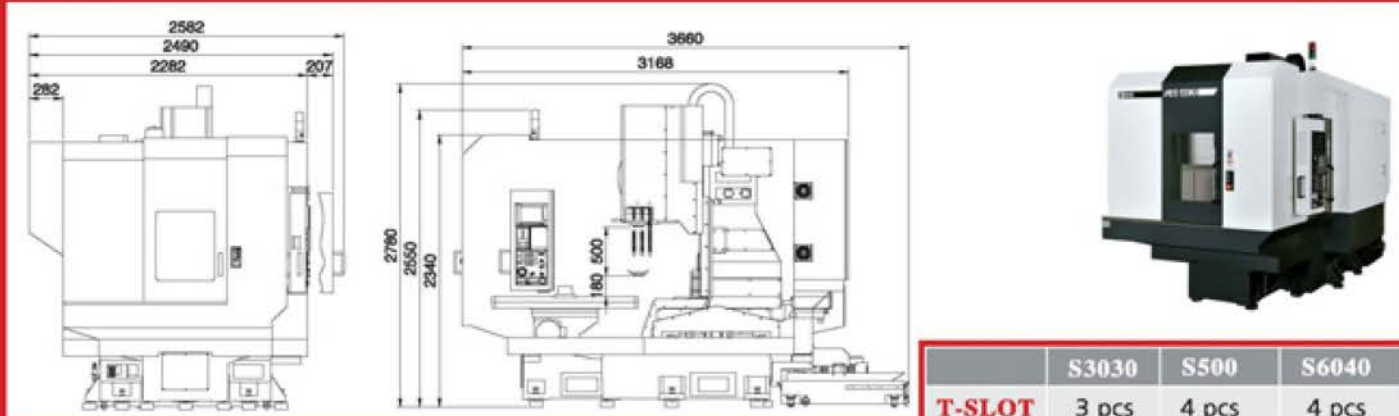

## SWING TABLES DIMENSIONS

Unit : mm

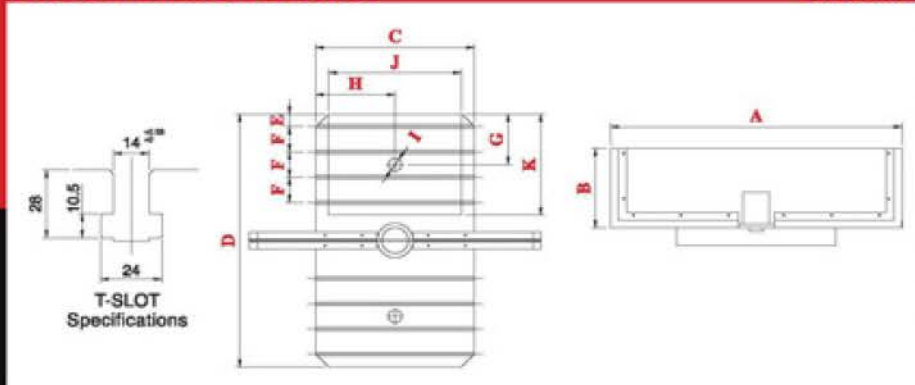

	S3030	S500	S6040
<b>T-SLOT</b>	3 pcs	4 pcs	4 pcs
<b>A</b>	800	1100	1400
<b>B</b>	290	315	415
<b>C</b>	400	600	700
<b>D</b>	700	1000	1200
<b>E</b>	45	50	55
<b>F</b>	80	100	125
<b>G</b>	—	200	180
<b>H</b>	—	300	350
<b>I</b>	—	Ø50 <sup>+0.03</sup> <sub>-0</sub>	Ø50 <sup>+0.03</sup> <sub>-0</sub>
<b>J</b>	300	500	600
<b>K</b>	250	400	400

★ The company reserves the right to modify the specifications / design, subject to change without further notice.  
Actual specifications, based on order content.

# S Series 3030/500/6040 CNC TAPPING CENTER

## MACHINE SPECIFICATIONS

		Unit	S3030	S500	S6040
Table size		mm	400 x 250 x 2 pcs	600 x 400 x 2pcs	700 x 400 x 2 pcs
Max. table load		kg	100	250	250
X, Y, Z axis travel		mm	300 x 250 x 250	500 x 400 x 350	600 x 400 x 500
Table to spindle nose		mm	180 ~ 430	180 ~ 530	180 ~ 680
Spindle taper			BT30	BT30	BT40
Pull stud			MAS403 P30T-1 (45°)	MAS403 P30T-1 (45°)	MAS403 P40T-1 (45°)
Spindle motor	Mitsubishi	kW	5.5 / 3.7	5.5 / 3.7	7.5 / 5.5
	FANUC	kW	3.7 / 2.2	3.7 / 2.2	7.5 / 5.5
	SIEMENS	kW	5.6 / 3.7	5.6 / 3.7	10.5 / 7.0
X drive motor	Mitsubishi	kW	1.5	1.5	3.5
	FANUC	kW	1.6	1.6	3.0
	SIEMENS	kW	2.3	2.3	3.3
Y drive motor	Mitsubishi	kW	1.5	1.5	3.5
	FANUC	kW	1.6	1.6	3.0
	SIEMENS	kW	2.3	2.3	3.3
Z drive motor	Mitsubishi	kW	1.5	1.5	3.5
	FANUC	kW	1.6	1.6	4.0
	SIEMENS	kW	3.3	3.3	4.9
Spindle speeds		rpm	10,000	10,000	8,000
X, Y, Z axis rapid traverse		m/min	48 / 48 / 48	36 / 36 / 48	36 / 36 / 48
Tools capacity		no.	14 / 20(OP)	20+1	24+1
Max. tool weight		kg	3	3	5
Max. tool length		mm	200	200	250
ATC time (T-T)		sec	M 1.9 / F 2.6	2.2	3.1
APC time		sec	3	4.5	5
Net weight		kg	3,350	5,250	6,600
Floor space		mm	2760 x 1730 x 2420	4130 x 2046 x 2370	3660 x 2582 x 2780

## CONTROLLER SPECIFICATIONS

	O : Standard			OP : Option		
	M80-B	0iMF	828D-PPU260	M80-B	0iMF	828D-PPU260
Max. number of controlled NC axes	5	5	4			
Max. simultaneous axis	4	4	4			
Standard controlled axis	3	3	3			
Program storage length	512kb	512kb	3M			
Work piece coordinates	54	54	100			
Max. variable number	700	600	300			
Tool offset pairs	400	400	128/256			
Conversational programming	NAVI	Manual guide Oi	Program Guide Shopmill(OP)			
Monitor	8.4" TFT LCD		10.4" LCD			
				Multi-language display	O	O
				ABS servo motor	O	O
				Tool length compensation	O	O
				Tool path compensation	O	O
				On-screen drafting	O	O
				High speed data server & ethernet	O	OP
				High speed & high accuracy machining control mode	G05 P10000	Q1
				Interface	RS232 / RJ45	RJ45
				Memory card input / output	O	O

★ Tool change time supplied with standard 60Hz power.  
For electrical requirements other than this standard, please contact one of our personnel.



## ARES MACHINERY CO., LTD.

No. 256, Tu-Cheng Rd., Da-Li, Taichung, Taiwan 41274  
Tel: +886-4-2492-5555 ares999@ms16.hinet.net  
Fax: +886-4-2496-6959 www.ares-seiki.com